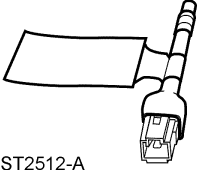
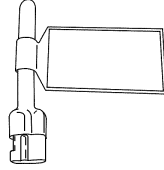
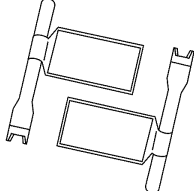

GENERAL PROCEDURES

Supplemental Restraint System (SRS) Deactivation and Reactivation

Special Tool(s)

 <p>ST2512-A</p>	<p>Diagnostic Tool, Restraint System 418-F403</p>
 <p>ST2507-A</p>	<p>Diagnostic Tool, Restraint System (2 required) 418-133</p>
 <p>ST2621-A</p>	<p>Diagnostic Tool, Restraint System (2 required) 418-F395</p>

Deactivation

⚠ WARNING: Always wear safety glasses when repairing an air bag supplemental restraint system (SRS) vehicle and when handling an air bag module. This will reduce the risk of injury in the event of an accidental deployment.

⚠ WARNING: After deployment, the air bag surface can contain deposits of sodium hydroxide, a product of the gas generant combustion that is irritating to the skin. Wash your hands with soap and water afterwards.

⚠ WARNING: Never probe the connectors on the air bag module. Doing so can result in air bag deployment, which can result in personal injury.

⚠ WARNING: The safety belt pretensioner is a pyrotechnic device. Always wear safety glasses when repairing an air bag equipped vehicle and when handling a safety belt buckle pretensioner or safety belt retractor pretensioner. Never probe a pretensioner electrical connector. Doing so could result in pretensioner or air bag deployment and could result in personal injury.

⚠ WARNING: To reduce the risk of personal injury, do not use any memory saver devices.

NOTE: If a seat equipped with a supplemental restraint system (SRS) component is being serviced, the SRS must be depowered.

NOTE: After diagnosing or repairing an SRS, the restraint system diagnostic tools must be removed before operating the vehicle over the road.

NOTE: The air bag warning lamp illuminates when the RCM fuse is removed and the ignition switch is ON. This is normal operation and does not indicate a supplemental restraint system (SRS) fault.

NOTE: The SRS must be fully operational and free of faults before releasing the vehicle to the customer.

All vehicles

1. Turn all vehicle accessories OFF.
2. Turn the ignition switch to OFF.
3. At the smart junction box (SJB), located in the RH lower kick panel, remove the cover and the restraints control module (RCM) fuse F2.17 (10A) from the SJB. For additional information, refer to the Wiring Diagram Manual.
4. Turn the ignition ON and visually monitor the air bag indicator for at least 30 seconds. The air bag indicator will remain lit continuously (no flashing) if the correct RCM fuse has been removed. If the air bag indicator does not remain lit continuously, remove the correct RCM fuse before proceeding.
5. Turn the ignition OFF.

GENERAL PROCEDURES (Continued)

6.  **WARNING:** To avoid accidental deployment and possible personal injury, the backup power supply must be depleted before repairing or replacing any front or side air bag supplemental restraint system (SRS) components and before servicing, replacing, adjusting or striking components near the front or side air bag sensors, such as doors, instrument panel, console, door latches, strikers, seats and hood latches.

The front impact severity sensor is located on the radiator support bracket.

The first row side impact sensors (if equipped) are located at or near the base of the B-pillars.

To deplete the backup power supply energy, disconnect the battery ground cable and wait at least one minute. Be sure to disconnect auxiliary batteries and power supplies (if equipped).

Disconnect the battery ground cable and wait at least one minute. For additional information, refer to Section 414-01.

7. Remove the 2 driver air bag module bolt caps from the steering wheel (1 shown).

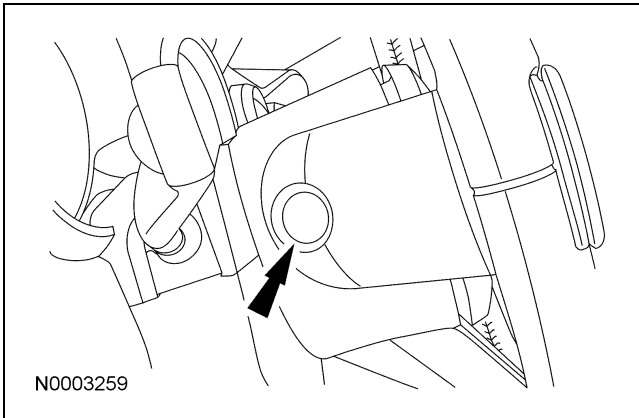

8. Remove the 2 driver air bag module bolts (1 shown).

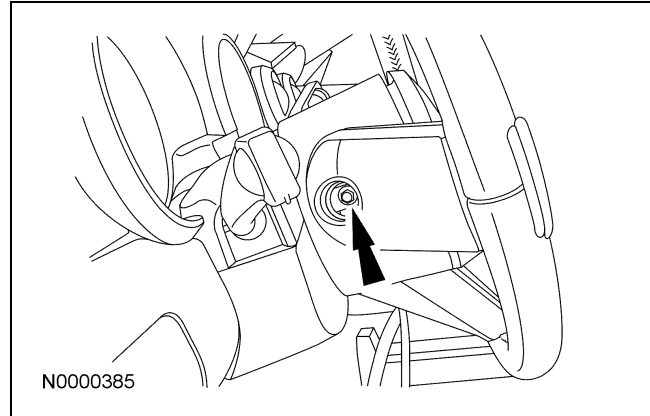

9. **NOTE:** Label the driver air bag module squib number on the driver air bag module electrical connectors before disconnecting.

Disconnect the 2 electrical connectors and remove the driver air bag module.

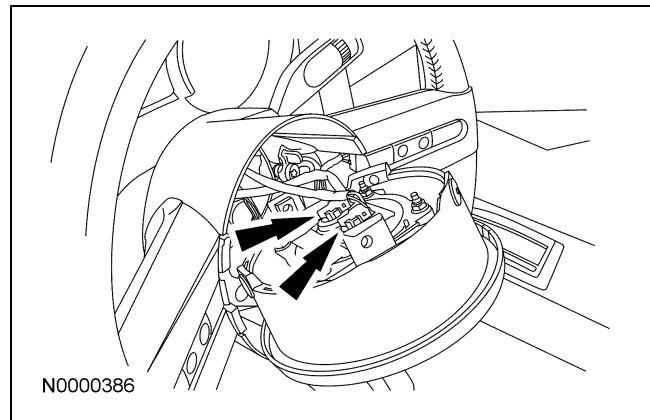

10. Attach the restraint system diagnostic tools to the clockspring electrical connectors at the top of the steering column.

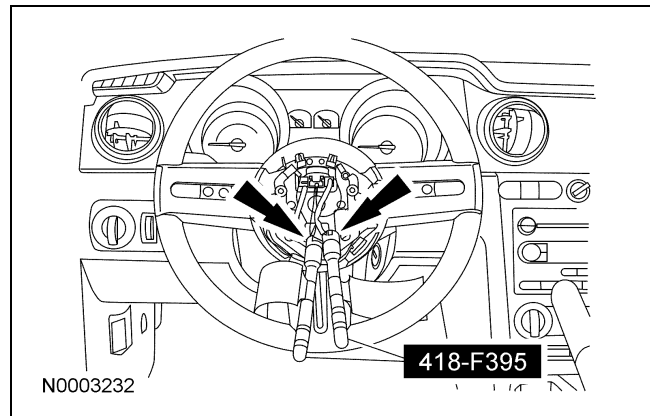

11. Fully lower the glove compartment door.

GENERAL PROCEDURES (Continued)

12. Disconnect the passenger air bag module electrical connector.

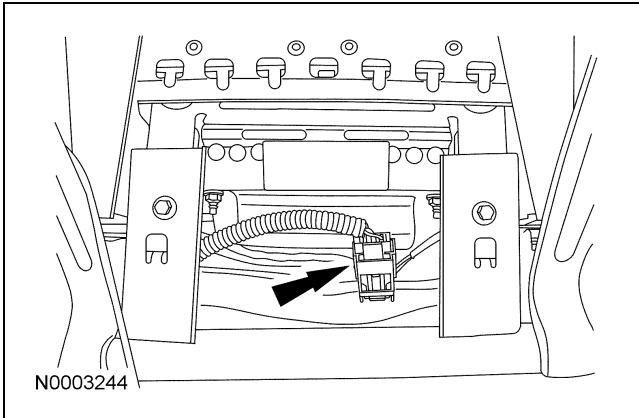

13. Attach the restraint system diagnostic tool to the vehicle harness side of the passenger air bag module electrical connector.

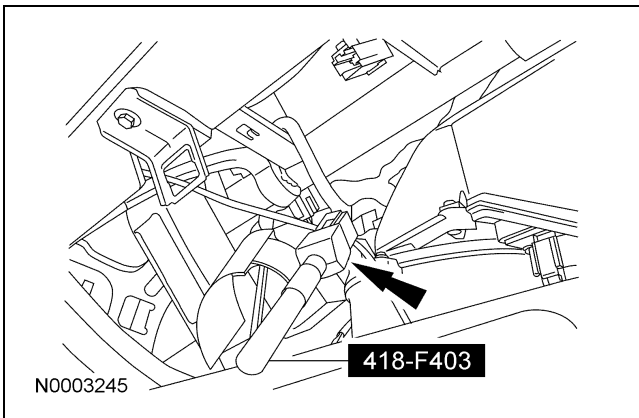
**Vehicles without seat side air bags**

14. **⚠ CAUTION: Do not deactivate the seat side air bag module circuit by removing the seat side air bag bridge resistor from the seat side air bag electrical connector.**

If the seat side air bag bridge resistor is removed, an open circuit fault will be generated by the restraints control module (RCM).

If a restraint system diagnostic tool is installed at the seat side air bag electrical connector, a low resistance fault will be generated by the RCM.

Vehicles with seat side air bags

15. Release the red locking tab and disconnect the passenger side air bag module electrical connector.

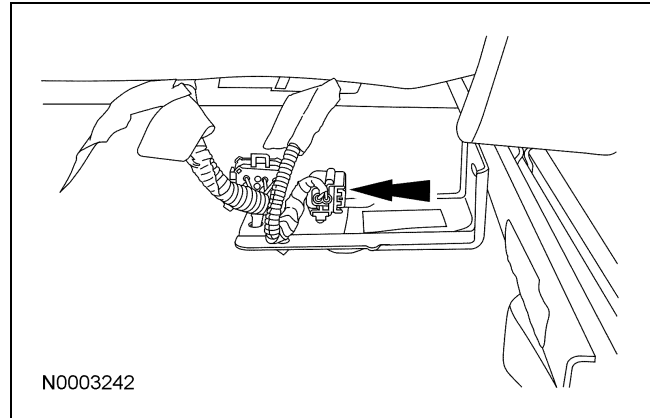

16. Attach the restraint system diagnostic tool to the vehicle harness side of the passenger side air bag module electrical connector.

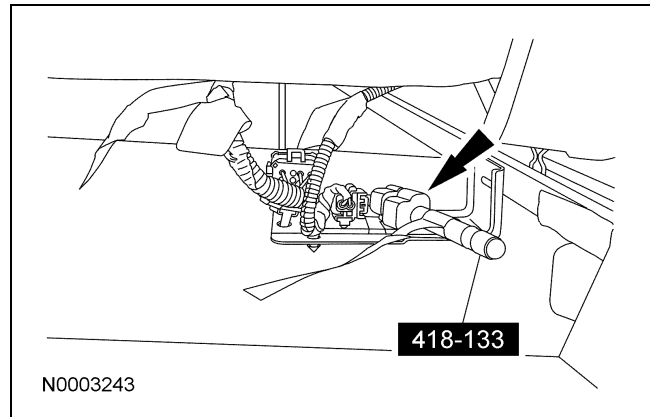

17. Release the red locking tab and disconnect the driver side air bag module electrical connector.

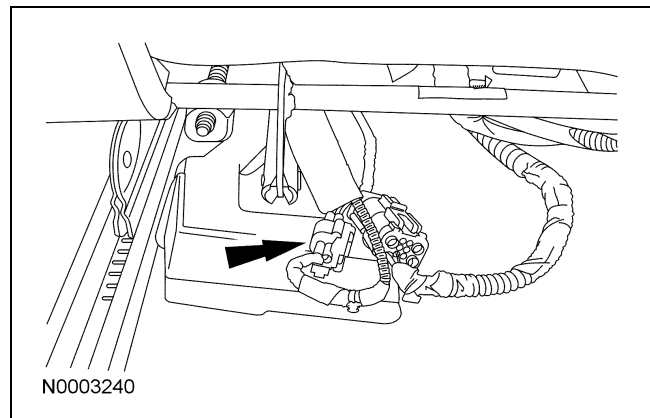

GENERAL PROCEDURES (Continued)

18. Attach the restraint system diagnostic tool to the vehicle harness side of the driver side air bag module electrical connector.

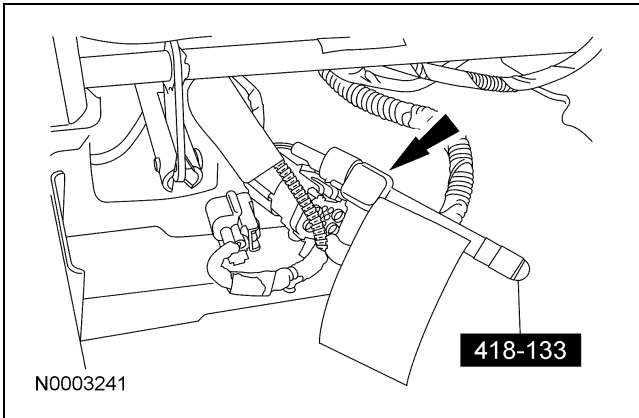

4. Connect the driver side air bag module electrical connector and reset the red locking tab.

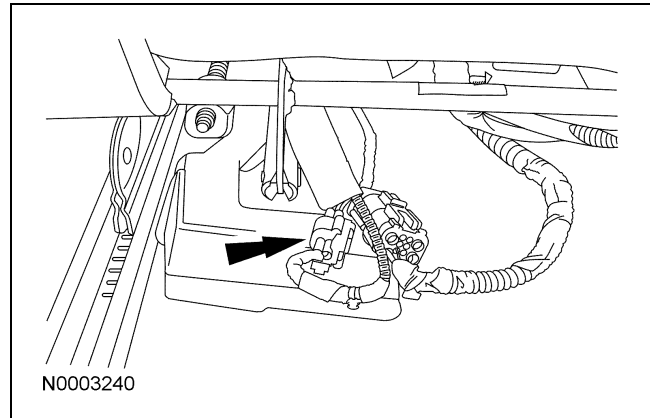
**All vehicles**

19. Install RCM fuse F2.17 (10A) to the SJB.
20. Connect the battery ground cable. For additional information, refer to Section 414-01.

Reactivation**All vehicles**

1. Remove RCM fuse F2.17 (10A) from the SJB.
2. Disconnect the battery ground cable and wait at least one minute.

5. Remove the restraint system diagnostic tool from the vehicle harness side of the passenger side air bag module electrical connector.

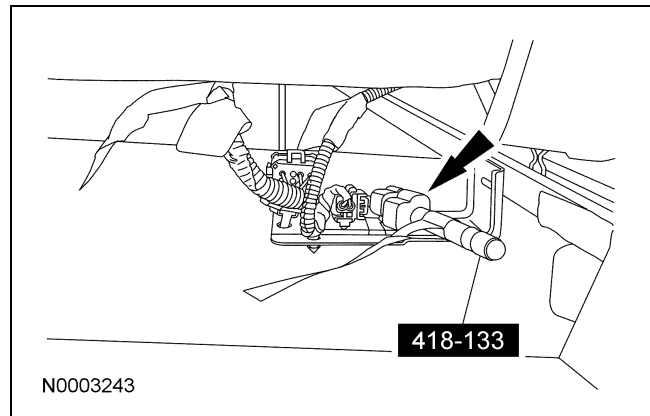
**Vehicles with seat side air bags**

3. Remove the restraint system diagnostic tool from the vehicle harness side of the driver side air bag module electrical connector.

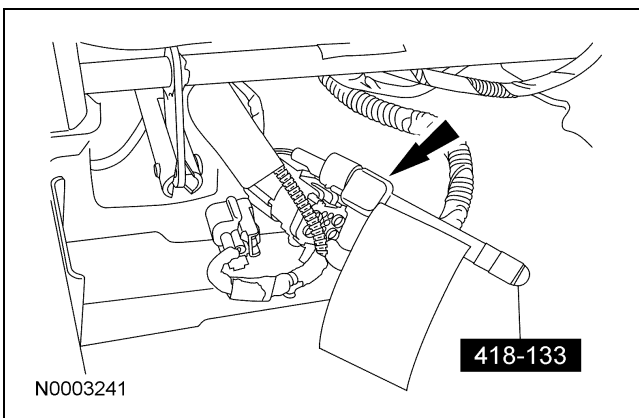

6. Connect the passenger side air bag module electrical connector and reset the red locking tab.

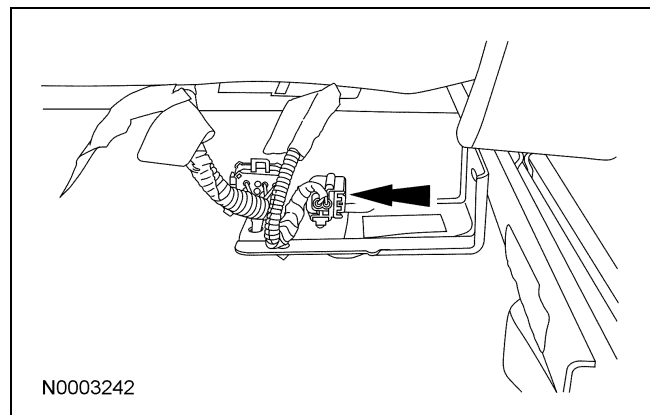

GENERAL PROCEDURES (Continued)**All vehicles**

7. Remove the restraint system diagnostic tool from the vehicle harness side of the passenger air bag module electrical connector.

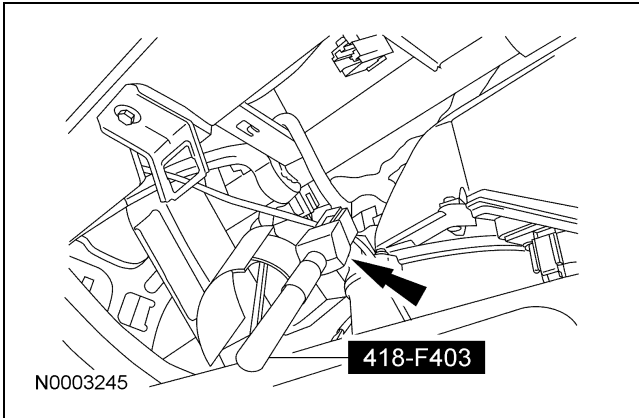

8. Connect the passenger air bag module electrical connector.

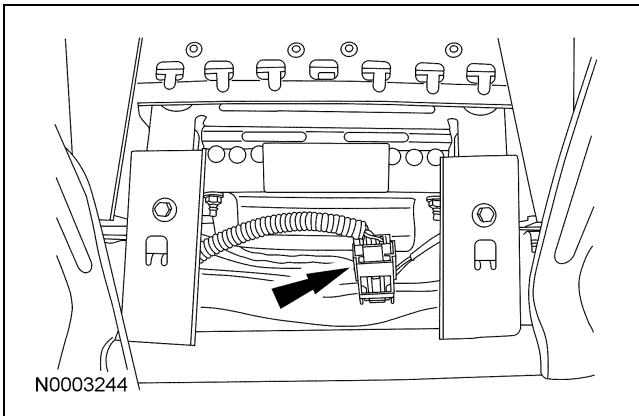

9. Close the glove compartment door.
10. Remove the restraint system diagnostic tools from the clockspring electrical connectors at the top of the steering column.

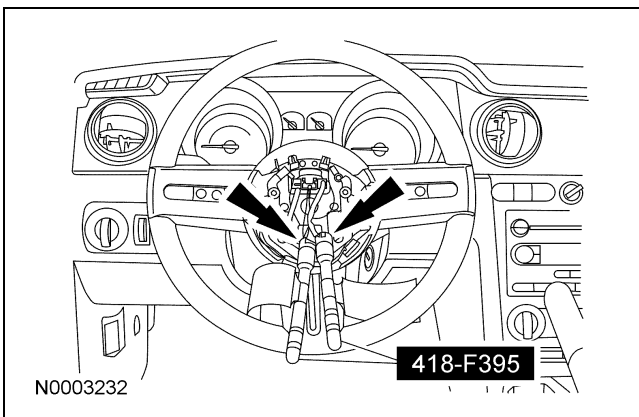

11. **⚠ CAUTION:** The clockspring electrical connectors are unique and cannot be reversed when connected to the driver air bag module. Match the electrical connector key to the keyway in the driver air bag module. Do not force the electrical connectors into the driver air bag module.

Connect the 2 electrical connectors and position the driver air bag module.

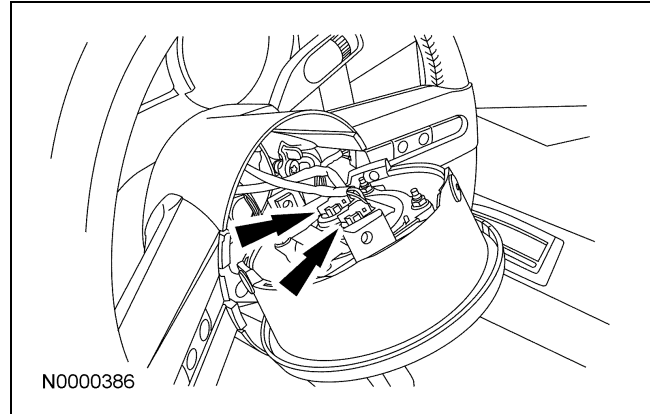

12. Install the 2 driver air bag module bolts (1 shown).
- Tighten to 7 Nm (62 lb-in).

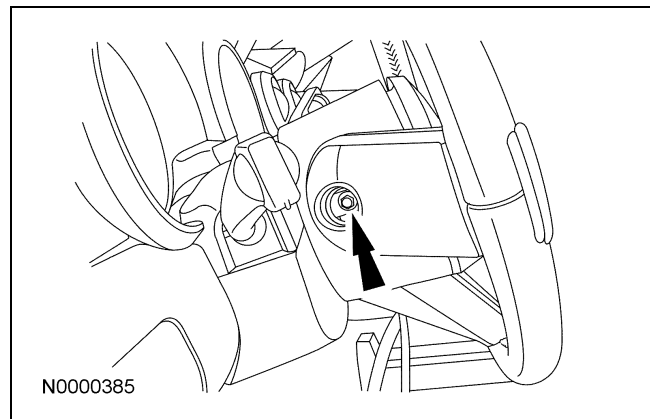

GENERAL PROCEDURES (Continued)

13. Install the 2 driver air bag module bolt caps in the steering wheel (1 shown).

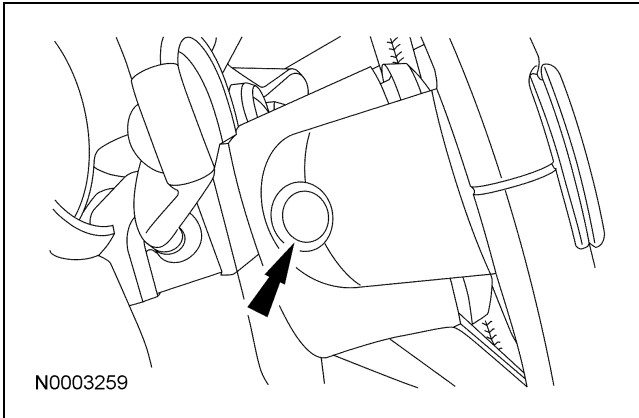

14. **⚠ WARNING: The restraint system diagnostic tool is for restraint system service only. Remove from vehicle prior to road use. Failure to remove could result in injury and possible violation of vehicle safety standards.**

Make sure all restraint system diagnostic tool(s) that may have been installed during the repair have been removed from the vehicle and all SRS components are connected.

15. Turn the ignition switch from OFF to ON.
16. Install RCM fuse F2.17 (10A) to the SJB and close the cover.
17. **⚠ WARNING: Be sure that nobody is in the vehicle and that there is nothing blocking or set in front of any air bag module when the battery ground cable is connected.**

Connect the battery ground cable.

18. Prove out the supplemental restraint system (SRS) as follows:

Turn the ignition key from ON to OFF. Wait 10 seconds, then turn the key back to ON and visually monitor the air bag indicator with the air bag modules installed. The air bag indicator will light continuously for approximately 6 seconds and then turn off. If an air bag supplemental restraint system (SRS) fault is present, the air bag indicator will:

- fail to light.
- remain lit continuously.
- flash.

The flashing might not occur until approximately 30 seconds after the ignition switch has been turned from the OFF to the ON position. This is the time required for the restraints control module (RCM) to complete the testing of the SRS. If the air bag indicator is inoperative and a SRS fault exists, a chime will sound in a pattern of 5 sets of 5 beeps. If this occurs, the air bag indicator and any SRS fault discovered must be diagnosed and repaired.

Clear all continuous DTCs from the restraints control module using a diagnostic tool.